

# PRPAC14

## PRODUCT SPECIFICATIONS

## 14 SEER ELECTRIC/ELECTRIC PACKAGED UNIT

FORM NO. PRPAC14-100 (01/2017)

### REFRIGERANT SYSTEM

- Environmentally friendly R410A refrigerant
- Copper tubing with enhanced fin coils
- Internal service gauge ports
- Sleeved distributor tubes
- Microban Antimicrobial Drain Pan
- High and Low Threaded pressure switches for system protection

### CABINET CONSTRUCTION

- Rounded corners for safety and an attractive, clean appearance
- One piece base design for strength and stability
- Drain ports for condensate management and coil runoff
- Low profile, with compact footprint
- Insulation to minimize heat loss plus reduce sound
- Textured pre-painted steel cabinet finish
- Superior service access to components
- Louvered coil guard protection
- One piece “no leak” top design

### BLOWER

- Insulated compartment to reduce sound
- Efficient multispeed motor for wide airflow range
- Slide out blower housing for easy service

### INSTALLATION

- Horizontal or down discharge capable
- Utility connections on “right side”
- Tabbed duct flanges for simple duct connections

### WARRANTY

10 year limited parts and compressor warranty. See limited warranty document for details.

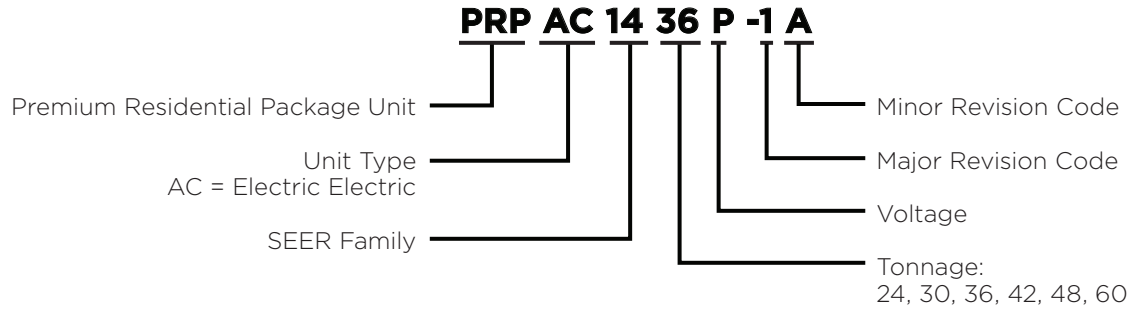

**MODEL NUMBER GUIDE****ELECTRICAL AND PHYSICAL DATA**

Model	Voltage	Phase	Hz	Min Volts @ 60 hz	MCA	Max Fuse/HACR Breaker	Compressor		Condenser Motor		Blower Motor		Refrig. Charge (oz.)	Weight (lbs.)
							RLA	LRA	RLA	HP	RLA	HP		
PRPAC1424	208-230	1	60	197	16.7	25	11.2	60.8	1.0	1/6	1.7	1/3	70	331
PRPAC1430							12.8	64			77	343		
PRPAC1436							14.1	72.2			79	351		
PRPAC1442							1.7	1/4	2.8	1/3	108	424		
PRPAC1448									2.8	1/2	106	428		
PRPAC1460									7.6	1	125	467		

**PERFORMANCE**

Model	Cooling					Sound dBA
	Rated AHRI Capacity Btuh	SEER	EER	Rated Sensible Capacity Btuh	CFM	
PRPAC1424	22,600	14.0	11.0	16,500	800	78
PRPAC1430	28,400			20,700	1000	
PRPAC1436	34,000			25,800	1200	
PRPAC1442	40,000			30,000	1400	
PRPAC1448	46,000			35,000	1600	
PRPAC1460	57,000			41,600	1800	

\*Certified in accordance with Unitary Air Conditioner Certification Program, which is based on AHRI Standard 210/240

**BLOWER PERFORMANCE**

MODEL	BLOWER TAP	CFM @ ext. Static Pressure in in. wc without filter, dry coil							
		0.1	0.2	0.3	0.4	0.5	0.6	0.7	0.8
PRPAC1424 PRPAC1430	2	1350	1310	1270	1210	1140	1080	1020	950
	3	1110	1080	1050	1000	970	920	870	800
	4	970	950	920	890	850	820	770	710
	5	840	820	800	770	750	720	680	620
PRPAC1436	2	1460	1380	1280	1190	1100	990	880	760
	3	1350	1280	1200	1130	1060	950	870	750
	4	1080	1030	960	900	830	750	700	650
PRPAC1442	2	1790	1740	1670	1590	1510	1410	1310	1210
	3	1500	1470	1430	1370	1310	1240	1140	1010
	4	1070	1050	1010	980	920	870	820	690
PRPAC1448	2	1970	1890	1790	1690	1600	1510	1400	1280
	3	1730	1690	1600	1540	1450	1360	1270	1150
	4	1520	1480	1430	1370	1310	1230	1140	1050
PRPAC1460*	1	2240	2200	2140	2100	2060	2020	1980	1950
	2	1920	1870	1820	1770	1720	1670	1450	1360
	3	1400	1320	1260	1200	1120	1060	980	900

\*TAPs 4 & 5 are for Electric Heat. Refer to rating plate for proper speed selection.

**COOLING PERFORMANCE - EXTENDED RATINGS**

Outdoor Model	Indoor Temp DB/ WB °F	Outdoor Temperature - DB °F														
		65°			82°			95°			105°			115°		
		Btuh	S/T	kW	Btuh	S/T	kW	Btuh	S/T	kW	Btuh	S/T	kW	Btuh	S/T	kW
PRPAC1424	85/72	31,700	0.62	1.45	29,100	0.63	1.73	27,100	0.64	1.95	25,000	0.71	2.13	22,900	0.78	2.31
	80/67	28,600	0.68	1.45	25,700	0.71	1.72	23,600	0.73	1.98	22,200	0.78	2.15	20,900	0.84	2.33
	75/63	26,100	0.70	1.46	24,000	0.72	1.75	22,300	0.75	1.96	20,800	0.81	2.15	19,400	0.87	2.34
	75/57	22,400	1.00	1.46	20,800	1.00	1.75	19,600	1.00	1.98	19,100	1.00	2.16	18,700	1.00	2.35
PRPAC1430	85/72	36,800	0.64	1.80	34,200	0.65	2.11	32,200	0.66	2.35	29,800	0.72	2.61	27,300	0.77	2.87
	80/67	33,100	0.72	1.78	31,400	0.72	2.07	28,900	0.73	2.34	26,900	0.78	2.60	24,800	0.84	2.87
	75/63	30,000	0.76	1.78	28,200	0.75	2.09	26,800	0.75	2.34	25,100	0.81	2.61	23,300	0.88	2.88
	75/57	27,500	1.00	1.79	25,000	1.00	2.11	23,200	1.00	2.35	22,900	1.00	2.61	22,600	1.00	2.87
PRPAC1436	85/72	45,000	0.68	2.20	41,300	0.67	2.58	38,400	0.67	2.87	36,100	0.71	3.19	33,700	0.76	3.50
	80/67	41,200	0.73	2.20	37,400	0.73	2.53	34,500	0.76	2.86	32,800	0.79	3.18	31,100	0.82	3.50
	75/63	38,500	0.75	2.19	35,300	0.78	2.58	32,900	0.80	2.87	31,000	0.83	3.18	29,100	0.85	3.49
	75/57	35,500	1.00	2.19	33,000	1.00	2.57	31,000	1.00	2.87	29,500	1.00	3.18	27,900	1.00	3.49
PRPAC1442	85/72	53,600	0.63	2.66	50,200	0.65	3.14	47,600	0.67	3.51	43,600	0.73	3.84	39,500	0.79	4.18
	80/67	50,200	0.69	2.65	46,000	0.73	3.08	42,700	0.75	3.50	39,500	0.81	3.84	36,300	0.87	4.19
	75/63	47,200	0.73	2.64	42,800	0.76	3.10	39,500	0.79	3.45	36,600	0.84	3.82	33,800	0.89	4.20
	75/57	42,800	1.00	2.63	38,500	1.00	3.09	35,300	1.00	3.44	34,000	1.00	3.82	32,700	1.00	4.20
PRPAC1448	85/72	64,900	0.63	3.15	58,200	0.66	3.63	53,100	0.69	3.99	48,600	0.74	4.38	44,100	0.78	4.76
	80/67	59,200	0.71	3.04	52,300	0.73	3.52	47,500	0.76	3.97	44,100	0.81	4.36	40,800	0.87	4.76
	75/63	53,200	0.74	3.02	47,400	0.78	3.51	42,900	0.81	3.89	40,500	0.85	4.32	38,000	0.89	4.75
	75/57	46,500	1.00	2.99	42,100	1.00	3.49	38,700	1.00	3.87	37,800	1.00	4.31	36,800	1.00	4.75
PRPAC1460	85/72	70,300	0.63	3.50	66,100	0.64	4.19	62,800	0.65	4.72	59,100	0.70	5.27	55,500	0.76	5.82
	80/67	65,700	0.69	3.47	61,000	0.71	4.08	57,400	0.73	4.69	54,300	0.78	5.24	51,200	0.83	5.78
	75/63	61,400	0.72	3.45	56,300	0.74	4.12	52,300	0.76	4.63	50,200	0.80	5.19	48,000	0.85	5.75
	75/57	54,500	1.00	3.42	50,100	1.00	4.09	46,700	1.00	4.61	46,300	1.00	5.17	45,900	1.00	5.73

**HEAT STRIP ELECTRICAL**

Model Number	Heater Model	Unit Supply Voltage Single Phase	Heater kW	Min. Circuit Ampacity 1	Max. Fuse / HACR Brkr. 1	Min. Circuit Ampacity 2	Max. Fuse / HACR Brkr. 2	Min. Circuit Ampacity Single Point	Max. Fuse / HACR Brkr. Single Point	
PRPAC1424	PHK05BP-1	240	5	27.7	30	-	-	27.7	30	
		208	3.8	24.3	25	-	-	24.3	25	
	PHK07BP-1	240	7.5	40.8	45	-	-	40.8	45	
		208	5.6	35.6	40	-	-	35.6	40	
	PHK10BP-1	240	10	53.8	55	-	-	53.8	55	
		208	7.5	46.8	50	-	-	46.8	50	
PRPAC1430	PHK05BP-1	240	5	27.7	30	-	-	27.7	30	
		208	3.8	24.3	25	-	-	24.3	30	
	PHK07BP-1	240	7.5	40.8	45	-	-	40.8	45	
		208	5.6	35.6	40	-	-	35.6	40	
	PHK10BP-1	240	10	53.8	55	-	-	53.8	55	
		208	7.5	46.8	50	-	-	46.8	50	
	PHK15CP-1	240	15	53.8	55	26	30	79.8	80	
		208	11.3	46.8	50	22.6	25	69.4	70	
	PRPAC1436	PHK05BP-1	240	5	28	30	-	-	28	30
			208	3.8	24.6	25	-	-	24.6	30
PHK07BP-1		240	7.5	41.1	45	-	-	41.1	45	
		208	5.6	35.9	40	-	-	35.9	40	
PHK10BP-1		240	10	54.1	55	-	-	54.1	55	
		208	7.5	47.1	50	-	-	47.1	50	
PHK15CP-1		240	15	54.1	55	26	30	80.1	90	
		208	11.3	47.1	50	22.6	25	69.7	70	
PRPAC1442		PHK05BP-1	240	5	28.8	30	-	-	28.8	40
			208	3.8	25.4	30	-	-	25.4	40
	PHK07BP-1	240	7.5	41.9	45	-	-	41.9	45	
		208	5.6	36.7	40	-	-	36.7	40	
	PHK10BP-1	240	10	54.9	55	-	-	54.9	55	
		208	7.5	47.9	50	-	-	47.9	50	
	PHK15CP-1	240	15	54.9	55	26	30	80.9	90	
		208	11.3	47.9	50	22.6	25	70.5	80	
	PHK20CP-1	240	20	54.9	55	52.1	60	107	110	
		208	15	47.9	50	45.1	50	93	100	
PRPAC1448	PHK05BP-1	240	5	28.8	30	-	-	28.8	40	
		208	3.8	25.4	30	-	-	26.9	40	
	PHK07BP-1	240	7.5	41.9	45	-	-	41.9	45	
		208	5.6	36.7	40	-	-	36.7	40	
	PHK10BP-1	240	10	54.9	55	-	-	54.9	55	
		208	7.5	47.9	50	-	-	47.9	50	
	PHK15CP-1	240	15	54.9	55	26	30	80.9	90	
		208	11.3	47.9	50	22.6	25	70.5	80	
	PHK20CP-1	240	20	54.9	55	52.1	60	107	110	
		208	15	47.9	50	45.1	50	93	100	

MODEL NO.	HEATER MODEL	Unit Supply Voltage Single Phase	Heater kW	Min. Circuit Ampacity 1	Max. Fuse / HACR Brkr. 1	Min. Circuit Ampacity 2	Max. Fuse / HACR Brkr. 2	Min. Circuit Ampacity Single Point	Max. Fuse / HACR Brkr. Single Point
PRPAC1460	PHK05BP-1	240	5	33.6	35	-	-	38.9	60
		208	3.8	30.2	35	-	-	38.9	60
	PHK07BP-1	240	7.5	46.7	50	-	-	46.7	60
		208	5.6	41.5	45	-	-	41.5	60
	PHK10BP-1	240	10	59.7	60	-	-	59.7	60
		208	7.5	52.7	55	-	-	52.7	60
	PHK15CP-1	240	15	59.7	60	26	30	85.7	90
		208	11.3	52.7	55	22.6	25	75.3	80
	PHK20CP-1	240	20	59.7	60	52.1	60	111.8	125
		208	15	52.7	55	45.1	50	97.8	100

## ACCESSORIES

Description	Where Used	Kit Number
Compressor Crankcase Heater	All	11X27
Compressor Hard Start Kit	24, 30, 36,60	10J42
Compressor Hard Start Kit	42,48	88M91
Compressor Timed-Off Control	All	47J27
Down Flow Conversion - ACONVR836	24, 30, 36	1.851401
Down Flow Conversion - ACONVR837	42,48,60	1.851402
Drain pan overflow switch	All	11U75
Electric Heater 5KW - PHK05BP	All	10W47
Electric Heater 7.5KW - PHK07BP	All	10W48
Electric Heater 10KW - PHK10BP	All	10W49
Electric Heater 15KW - PHK15CP	30,36,42,48,60	10W50
Electric Heater 20KW - PHK20CP	42,48,60	10W51
Filter Rack Kit	24, 30, 36	11U73
Filter Rack Kit	42,48,60	11U74
Lifting Brackets	All	11U76
Roof Curb	24, 30, 36	11U78
Roof Curb	42,48,60	11U79
Sideflow Rect. to 14" Rounds Duct Adapter (Qty 25 sets)	24, 30, 36	R104617-01
	42, 48, 60	R104618-01
8" Height Full Perimeter Curb	24, 30, 36	14W71
8" Height Full Perimeter Curb	42, 48, 60	14W72
14" Height Full Perimeter Curb	24, 30, 36	14V68
14" Height Full Perimeter Curb	42, 48, 60	14V69

Single Point Power		
5 KW ASPWR813-1	All	13W88
7.5 KW ASPWR814-1	All	13W89
10 KW ASPWR815-1	All	13W90
15-20 KW ASPWR816-1	30,36,42,48,60	13W91

**DIMENSIONS (IN.)**

Model	A	B	C	D	E	F	G	H	J
PRPAC1424	36.82	46.77	13.33	13.31	5.86	16.75	14	30.13	25.54
PRPAC1430									
PRPAC1436									
PRPAC1442	40.88	55.27	18.14	18.14	4.67	19.75	19.5	34.13	29.54
PRPAC1448									
PRPAC1460									

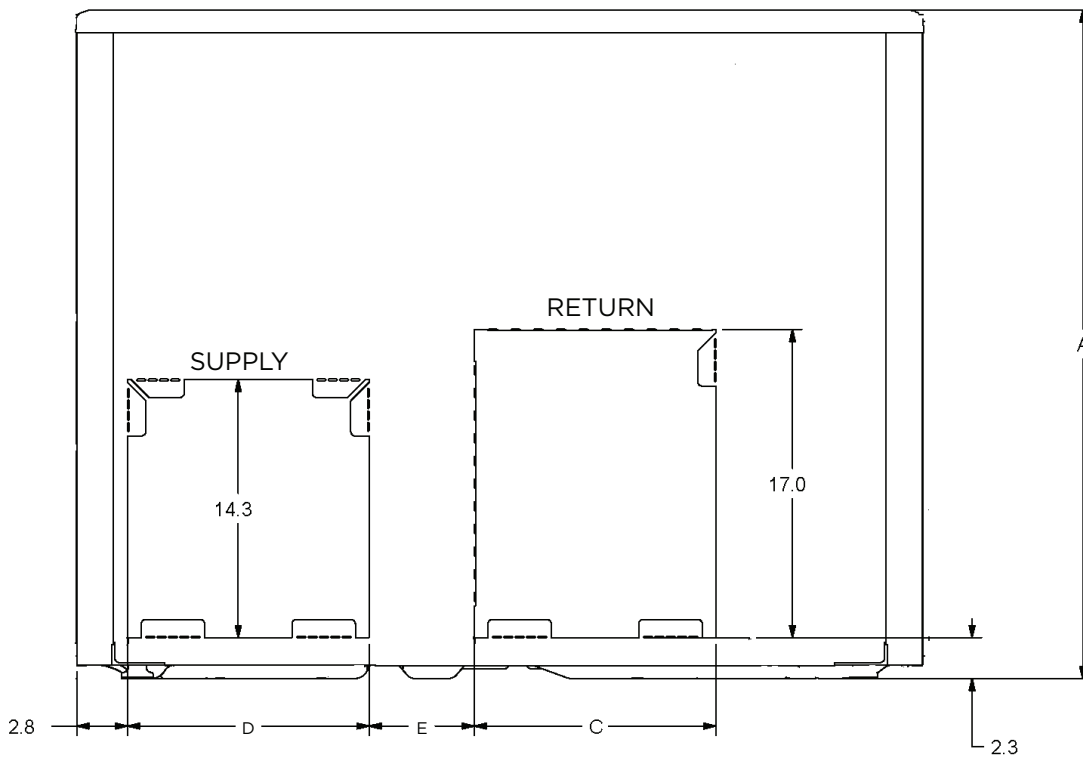
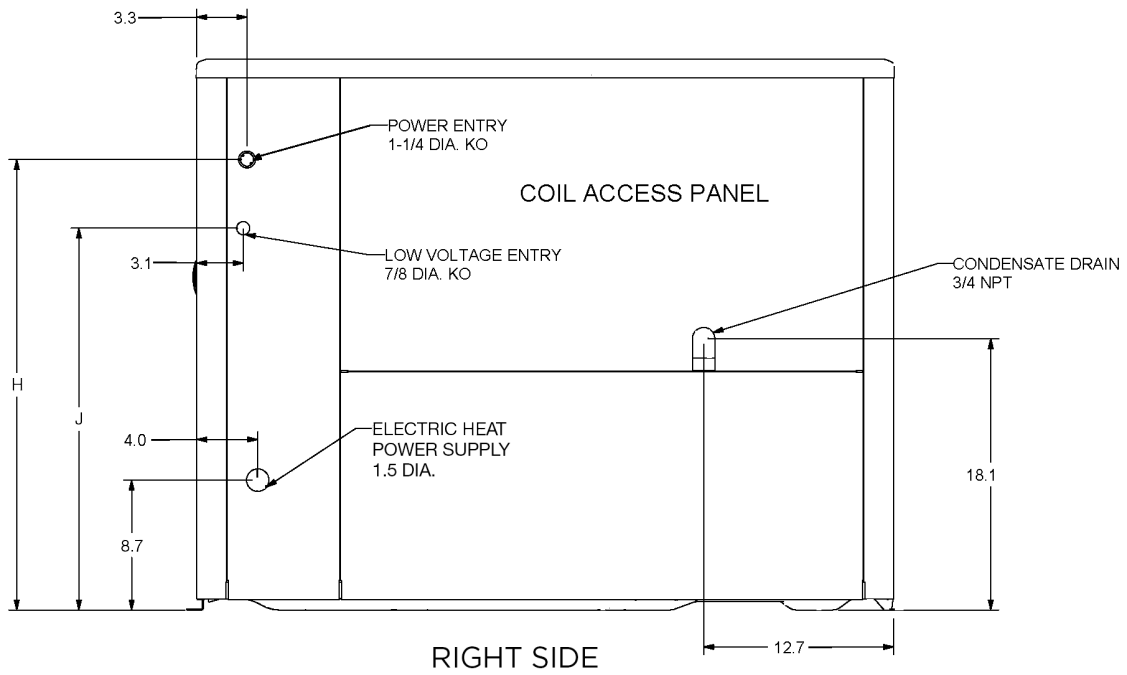

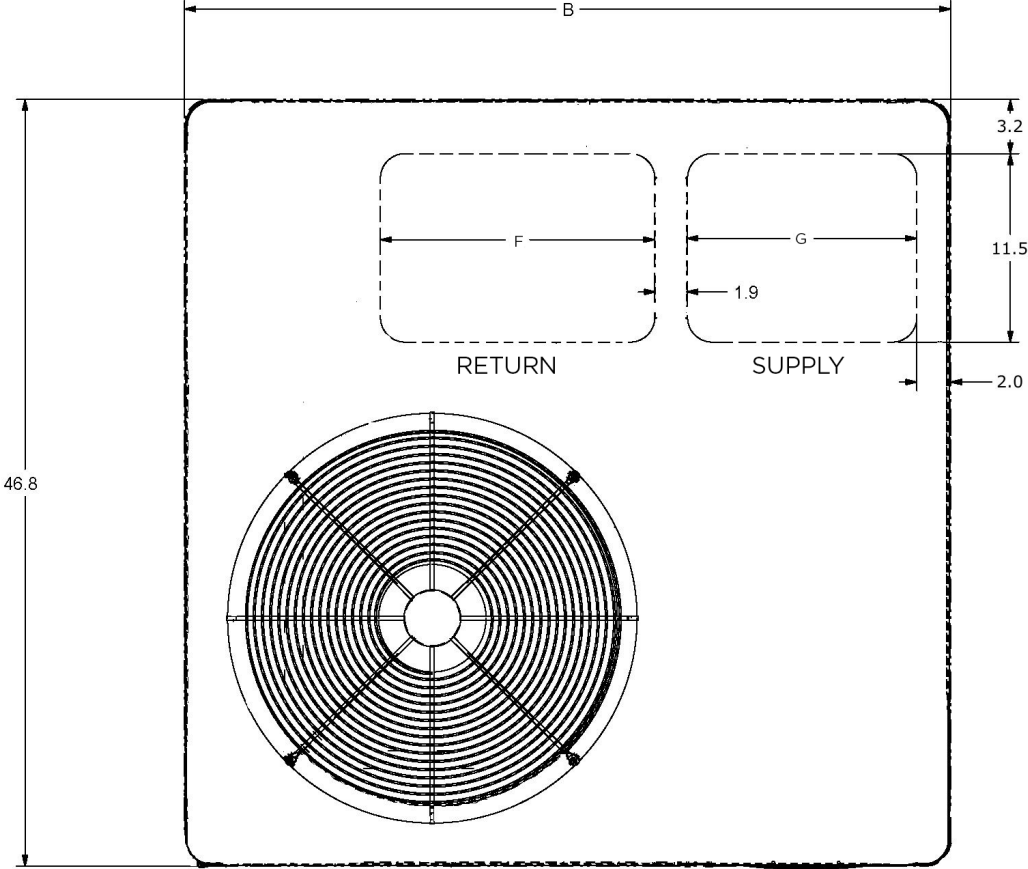

TOP - WITH BOTTOM DUCT SHOWN

**ROOF CURB DIMENSIONS**

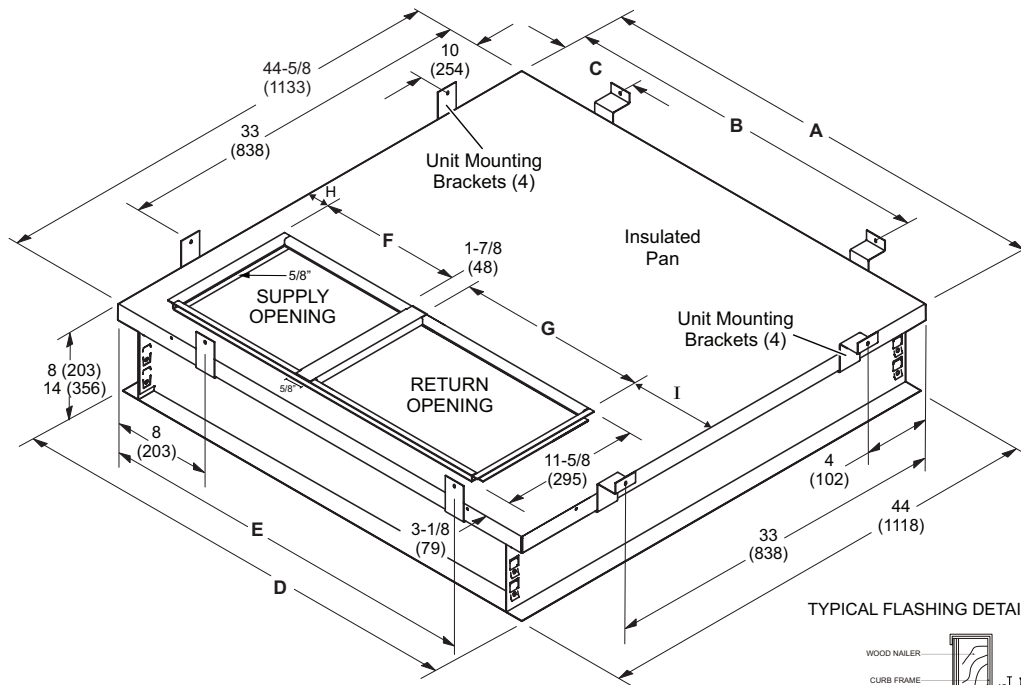

NOTE - Roof deck may be omitted within confines of curb.

TYPICAL FLASHING DETAIL

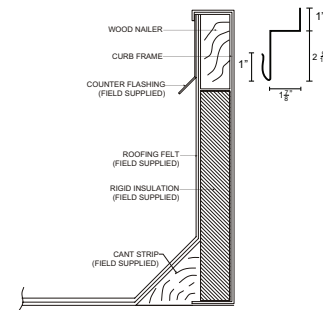

Usage	A		B		C		D		E	
	in.	mm	in.	mm	in.	mm	in.	mm	in.	mm
24, 36	44-5/8	1133	43	1092	18	457	44	1118	37	940
48, 60	53-1/8	1349	51	1295	24	610	52-1/2	1334	41	1041
Usage	F		G		H		I			
	in.	mm	in.	mm	in.	mm	in.	mm		
24, 36	16.75	356	14	425	2	51	9-3/4	248		
48, 60	19.75	495	19.50	502	2	51	10	254		



1-800-448-5872

All specifications and illustrations subject to change without notice and without incurring obligations.